



# Aachen Cathedral, Germany



Cut out the parts, and closely follow the instructions for assembly.



**Tools & Materials**

- Scissors, utility knife
- Glue (liquid glue, woodworking glue)
- A ruler or set square
- A pencil
- An object with a pointed tip (a dried-up ballpoint pen, stencil pen etc)
- Toothpicks
- Tweezers (useful for handling small parts)



**Tips for Assembly**

- Assembly will be easier if you write each part's number in pencil on the back of the part, to keep track of which part is which.
- Use a dried-up ballpoint pen, stencil pen, or another pointed object and a ruler to score along the fold lines. This will create sharper, neater folds.
- Before gluing, fold and crease along the fold lines and add curves where needed.
- Use a toothpick to apply a thin layer of glue, for a neater finish.



















**Caution**

- This paper craft uses scissors, utility knives, glue, and other items and materials which may be dangerous to young children, so please keep them out of reach of children while you work.
- When using scissors, utility knives etc, please take ample care not to cut yourself.



**Notation Key**

-  Pattern
-  Assembly Instructions
- (1), (2), (3)... Parts Number
-  Mountain fold line (dotted line)
-  Valley fold line (dotted & dashed line)
-  Scissors line (solid line)
-  Cut in line (solid red line)
-  Cut out part
-  Apply glue (red arrow)
-  Insert (blue arrow) (Do not apply glue)
-  Add curves
-  A glue tab (marked with a dot) marks where to apply glue.
-  Glue tab (red dot) Attach to another part
-  Glue tab (green dot) Attach within the same part
-  Glue tab (blue dot) Attach to the reverse side of another part
-  Glue tab (yellow dot) Attach the reverse sides of two parts together

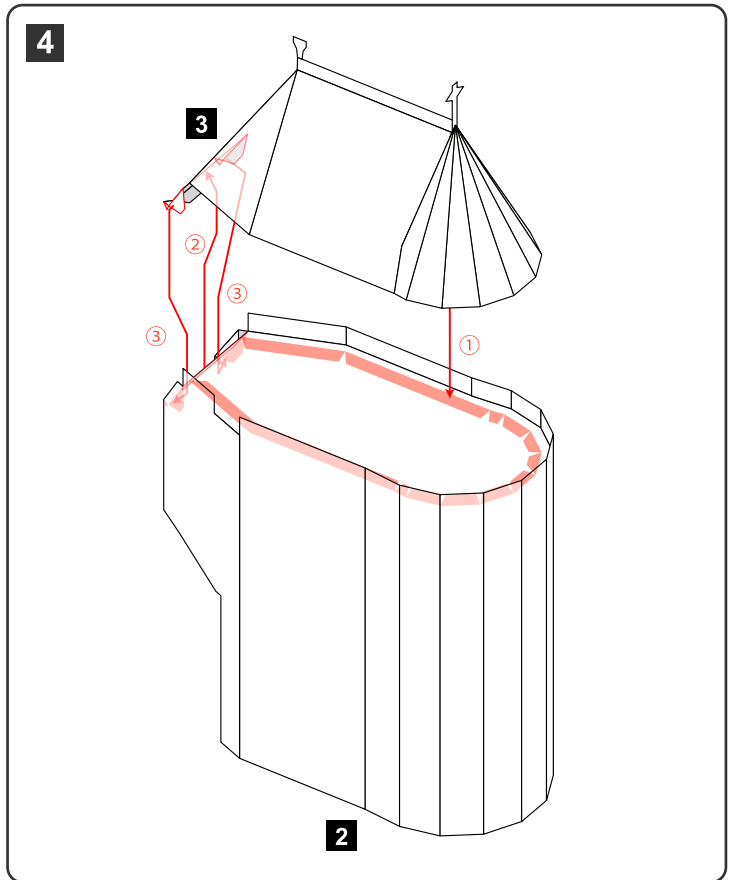
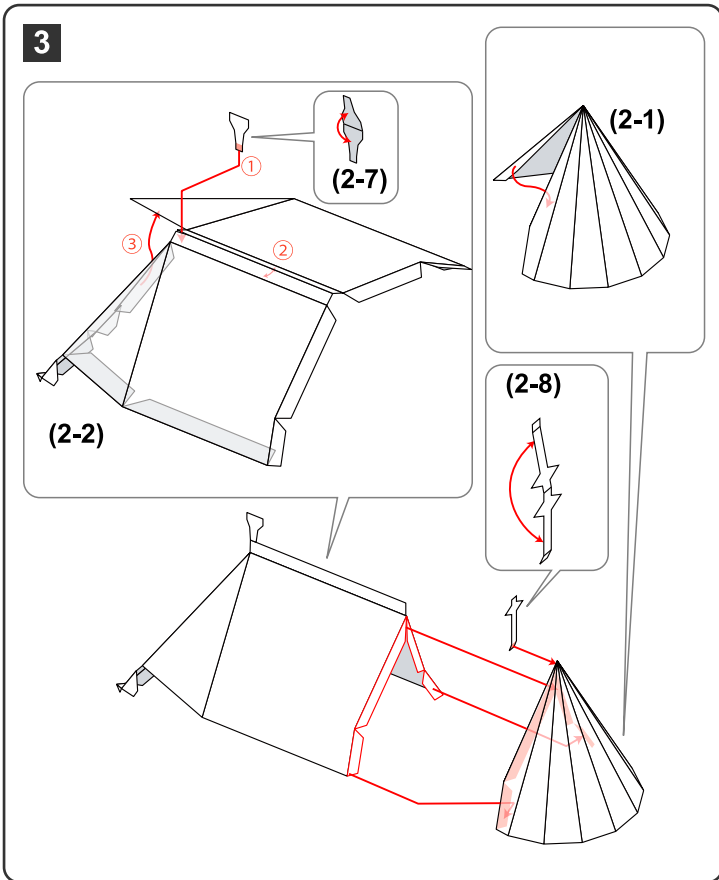
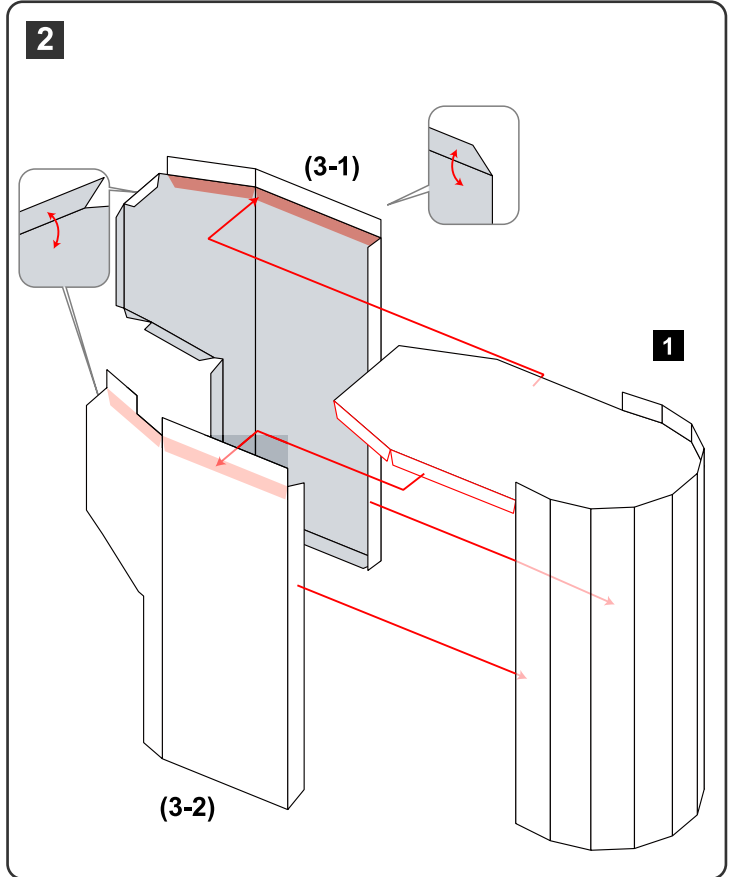
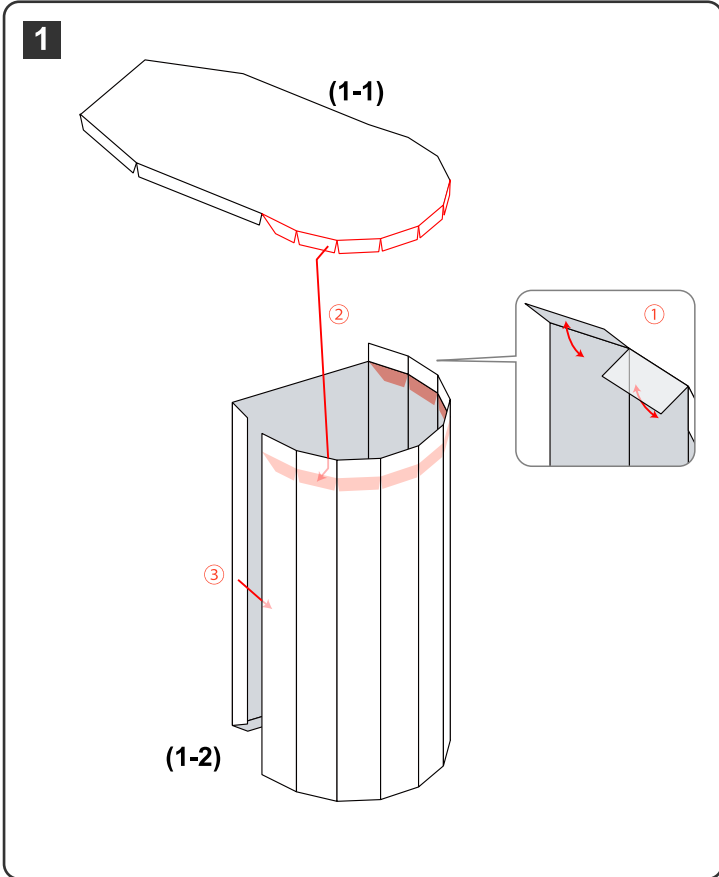





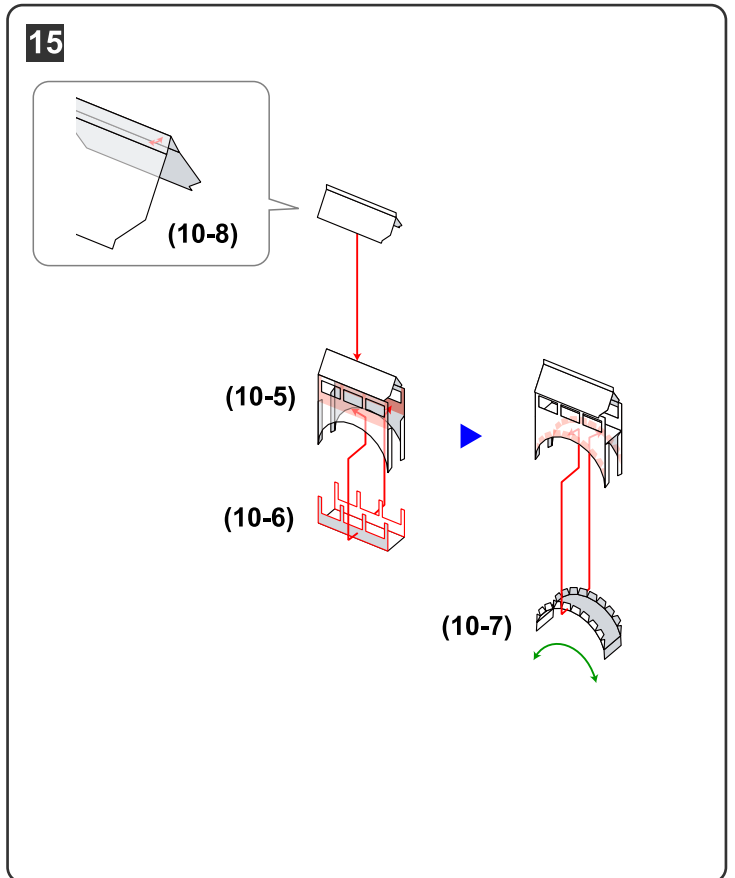
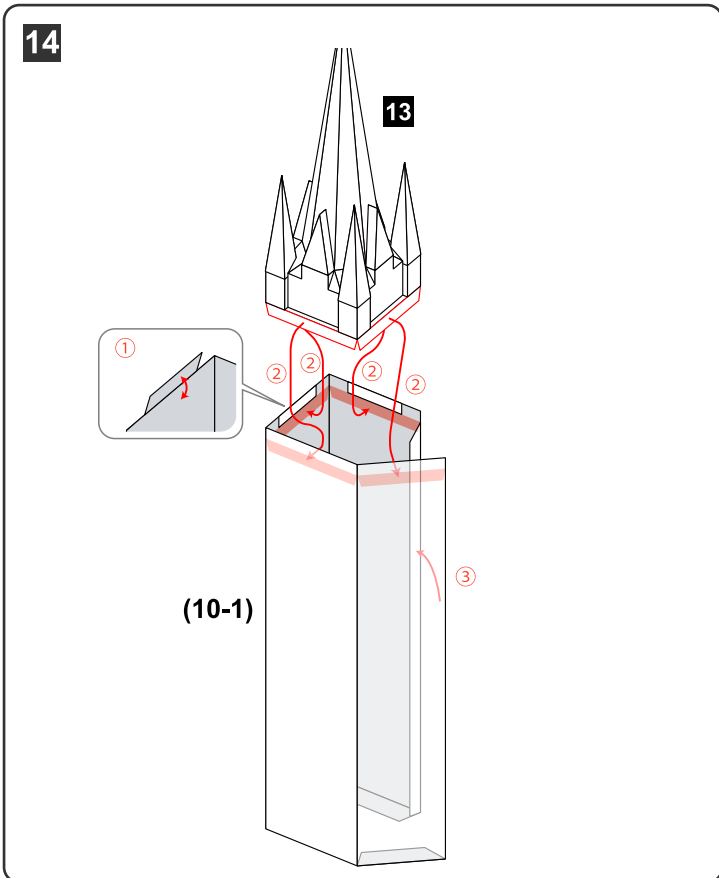
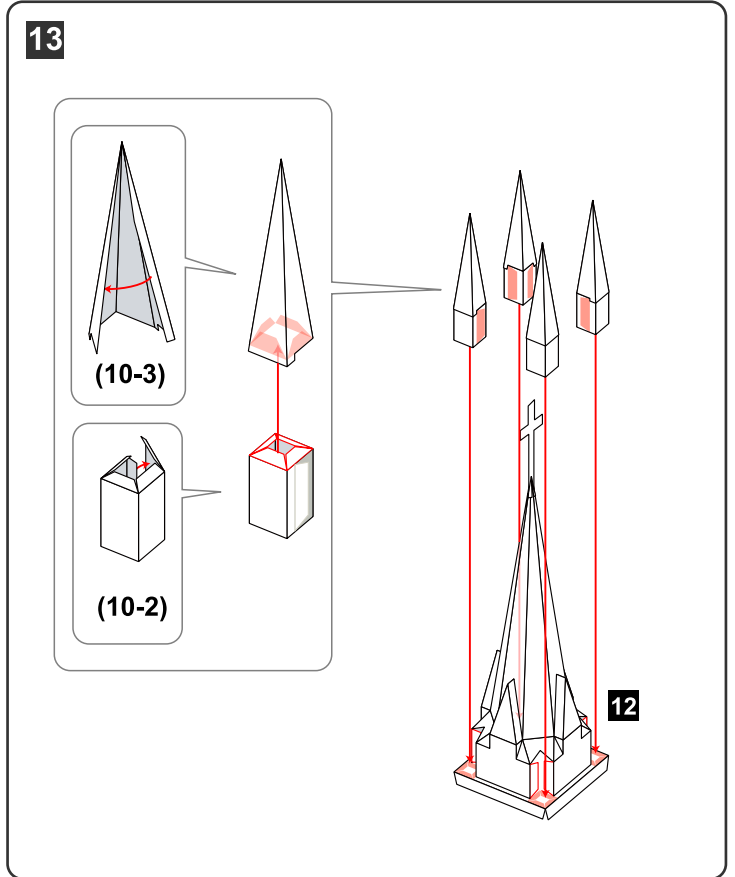
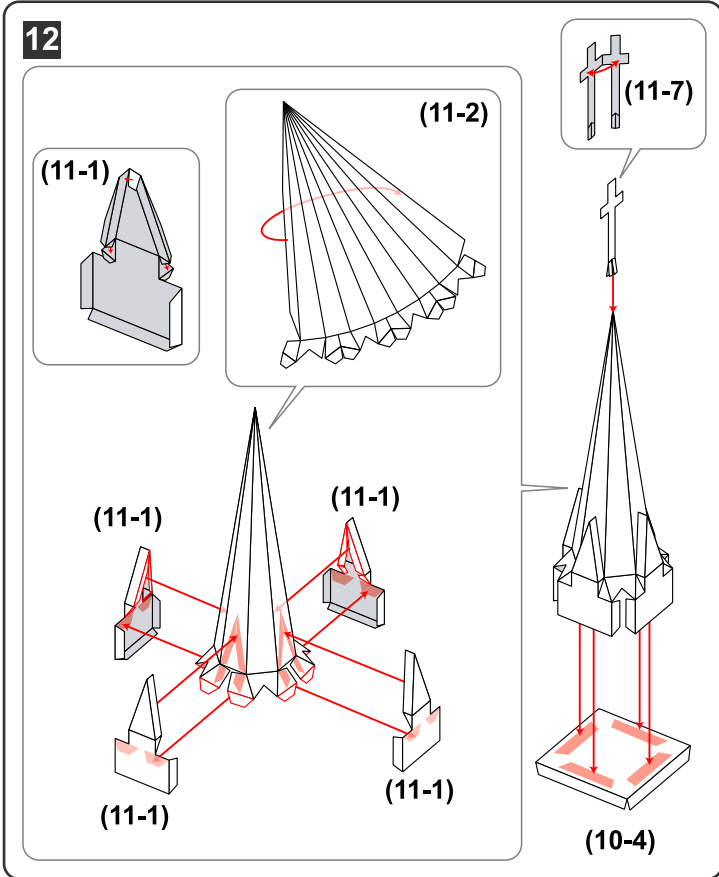

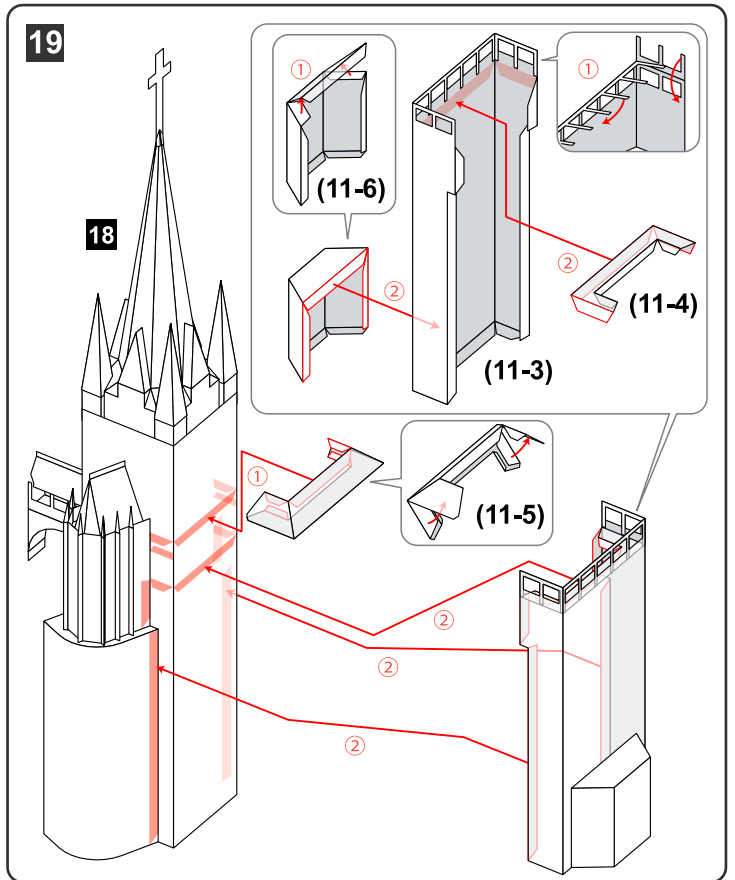
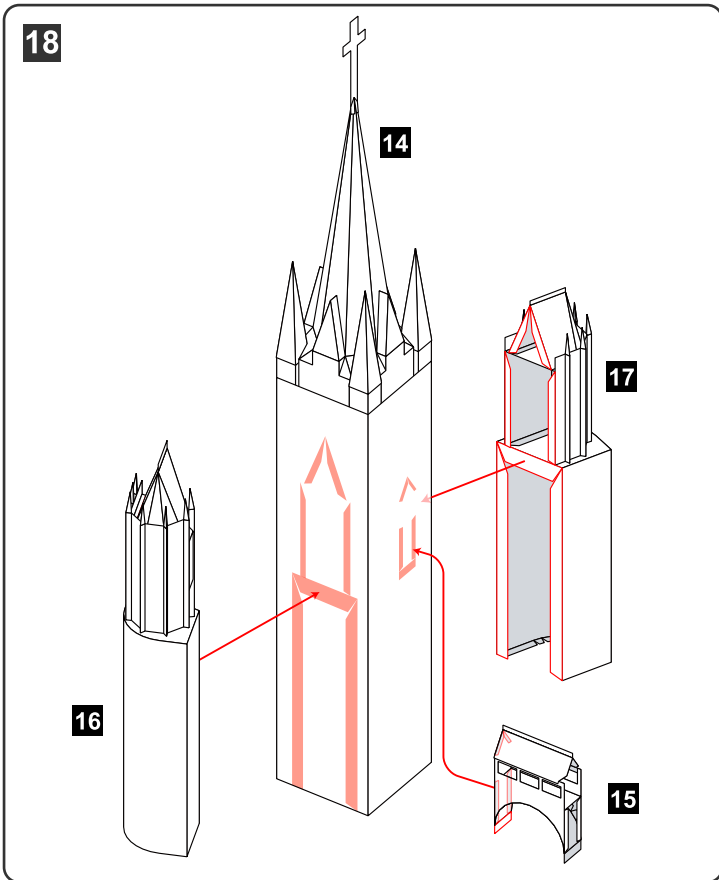
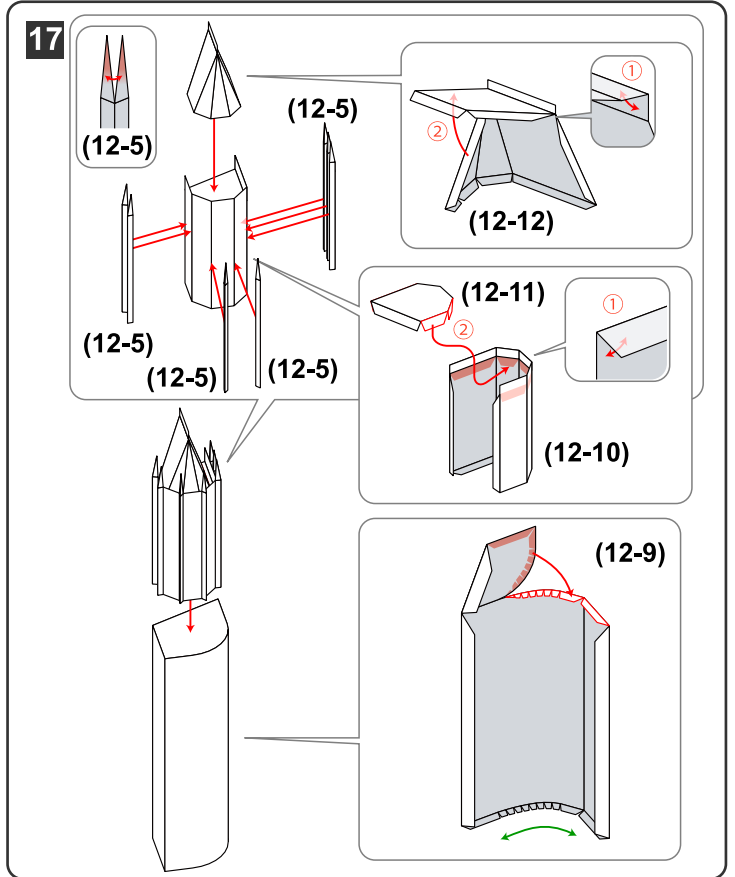
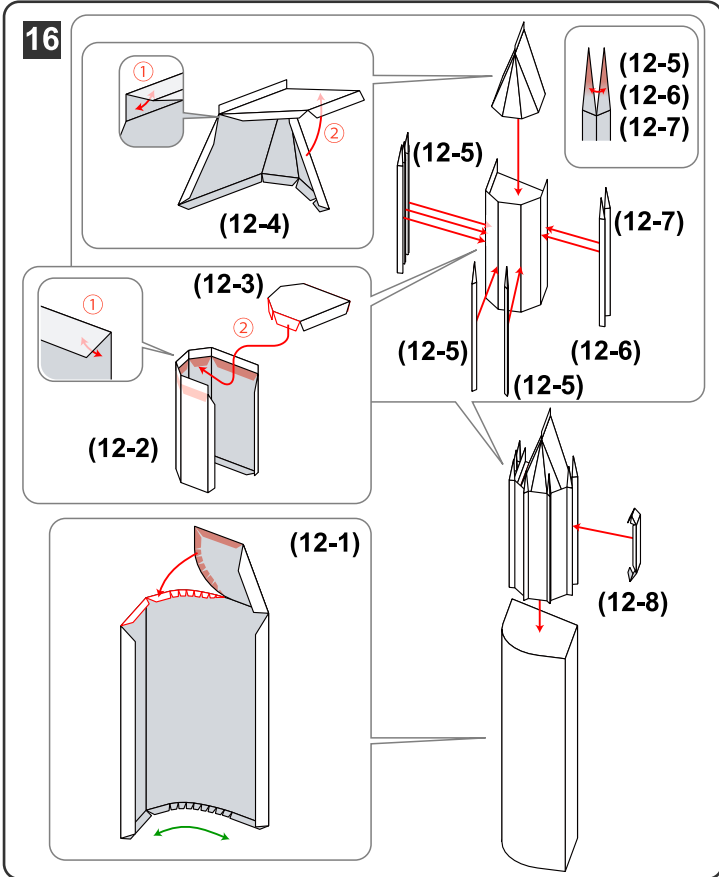

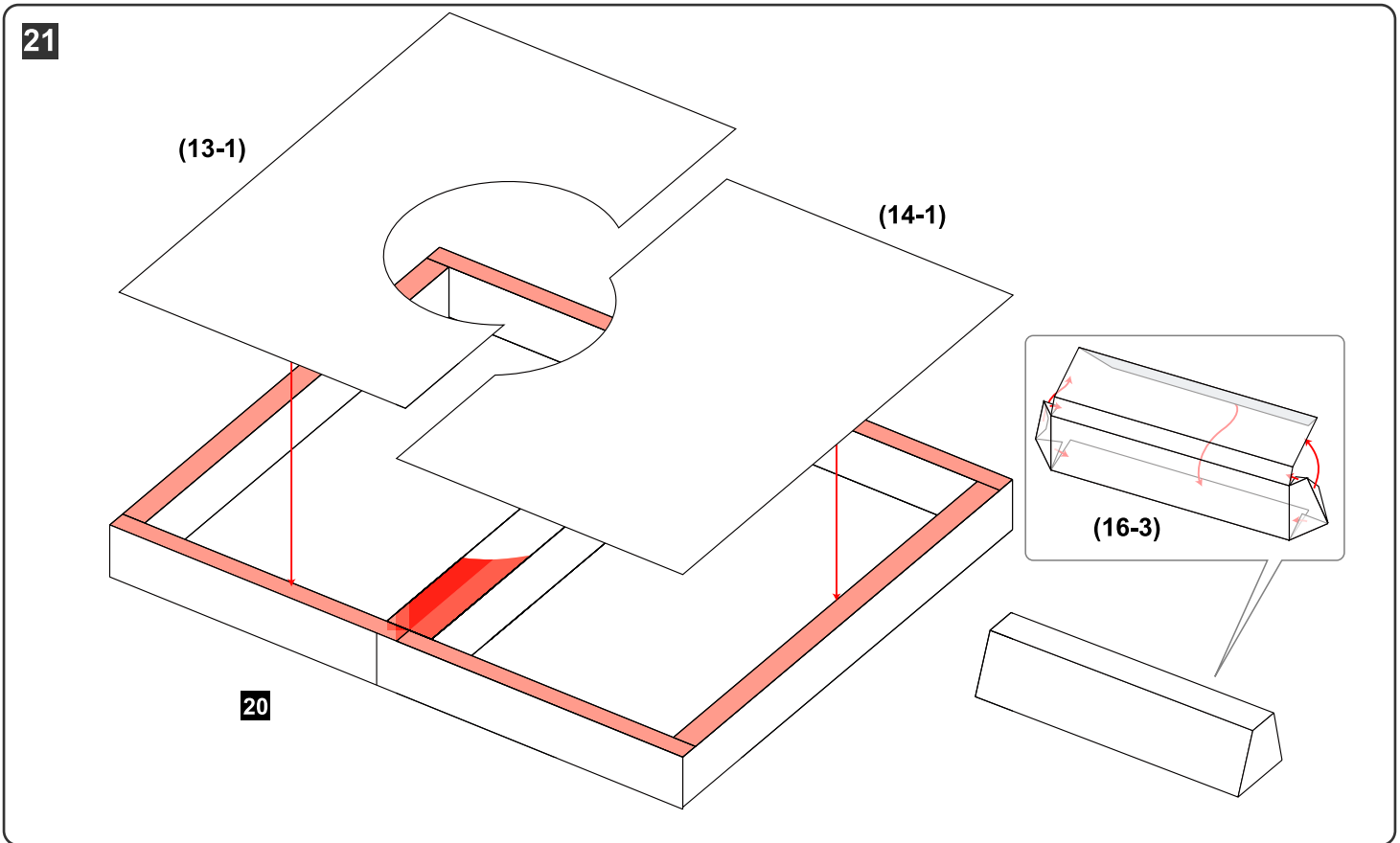
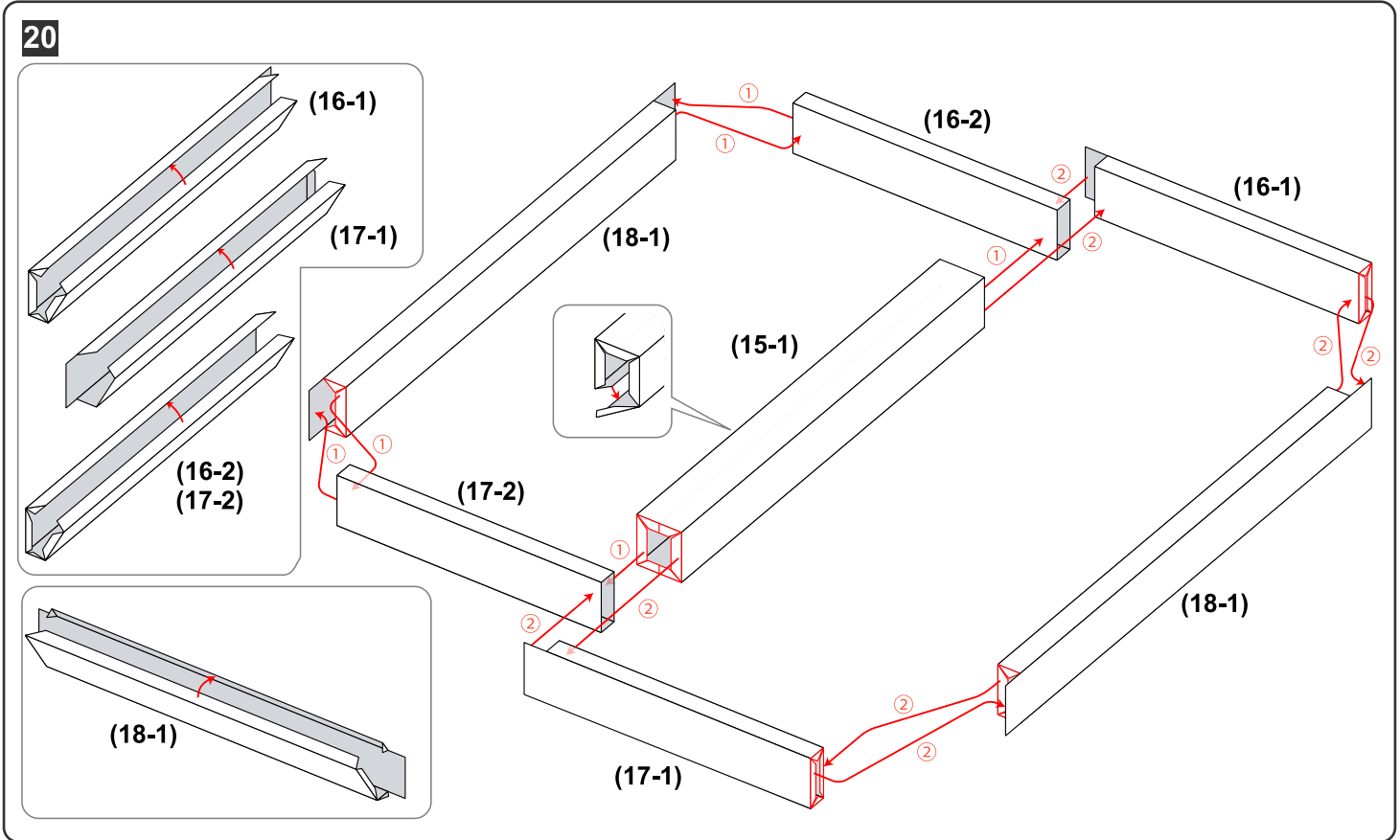

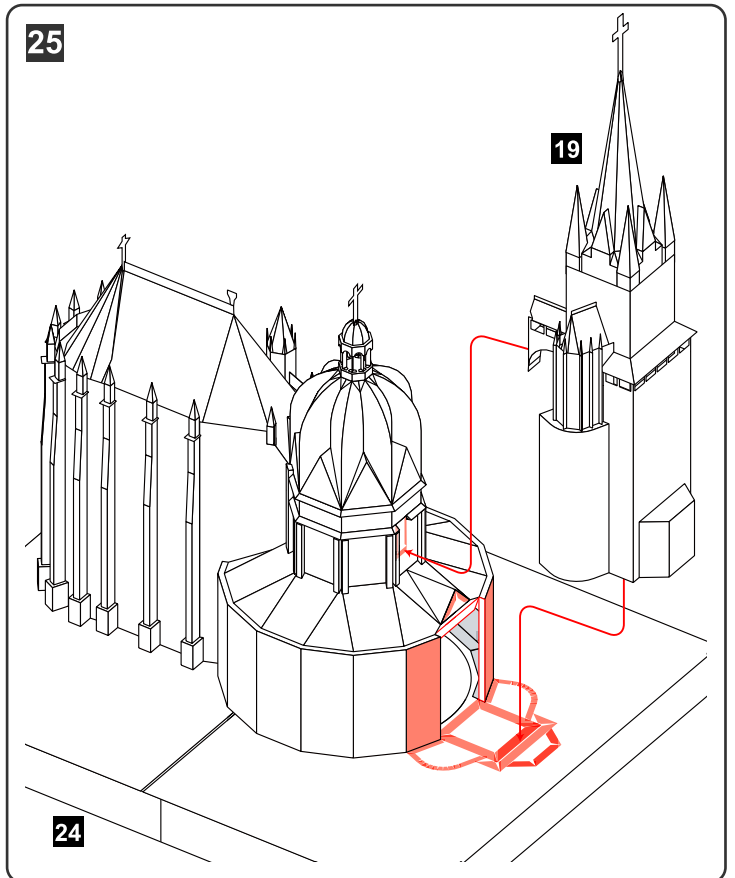
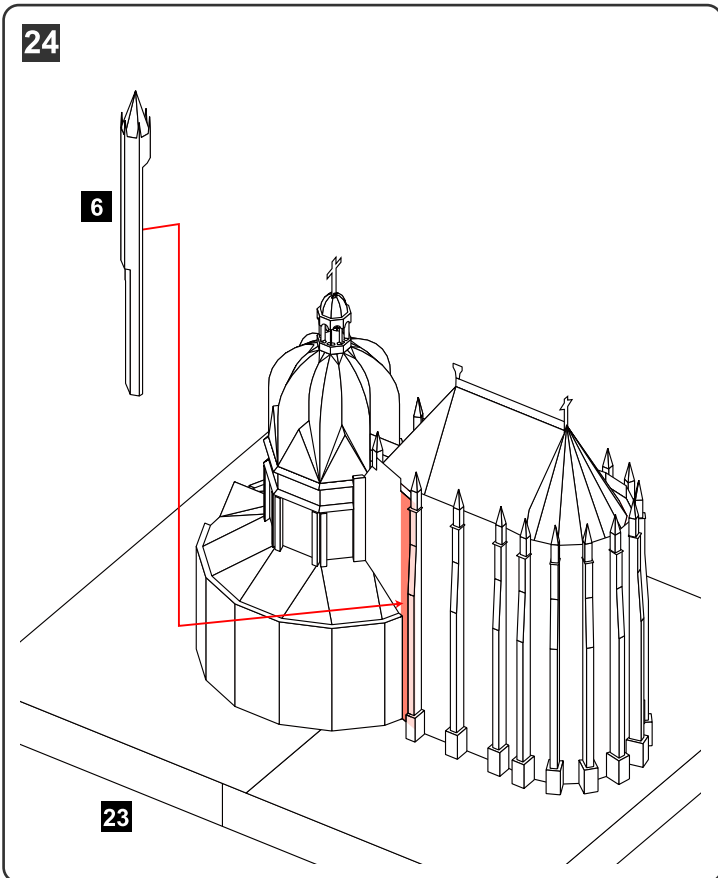
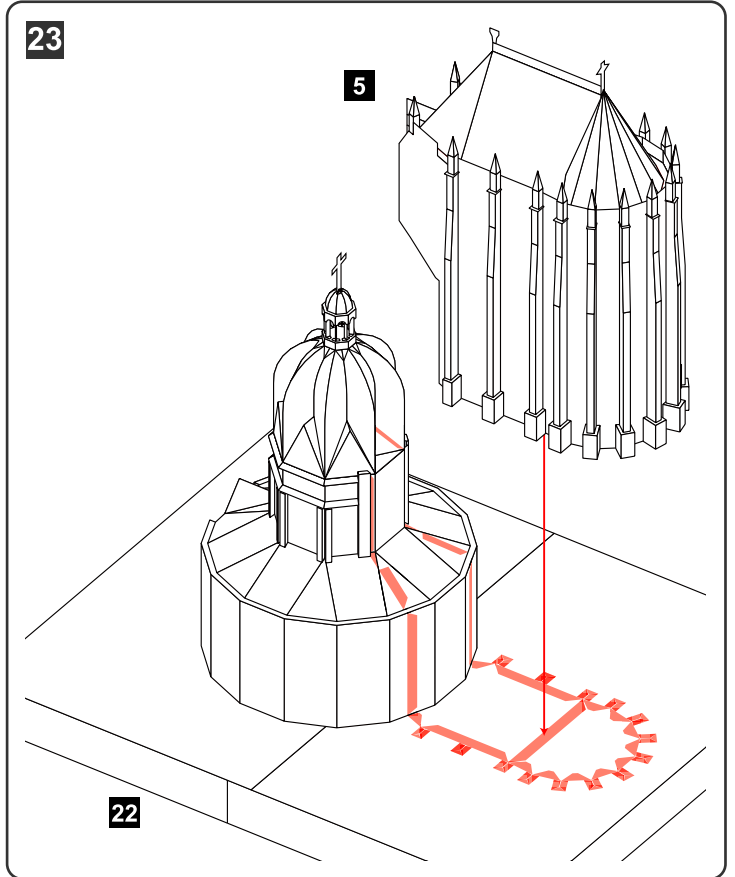
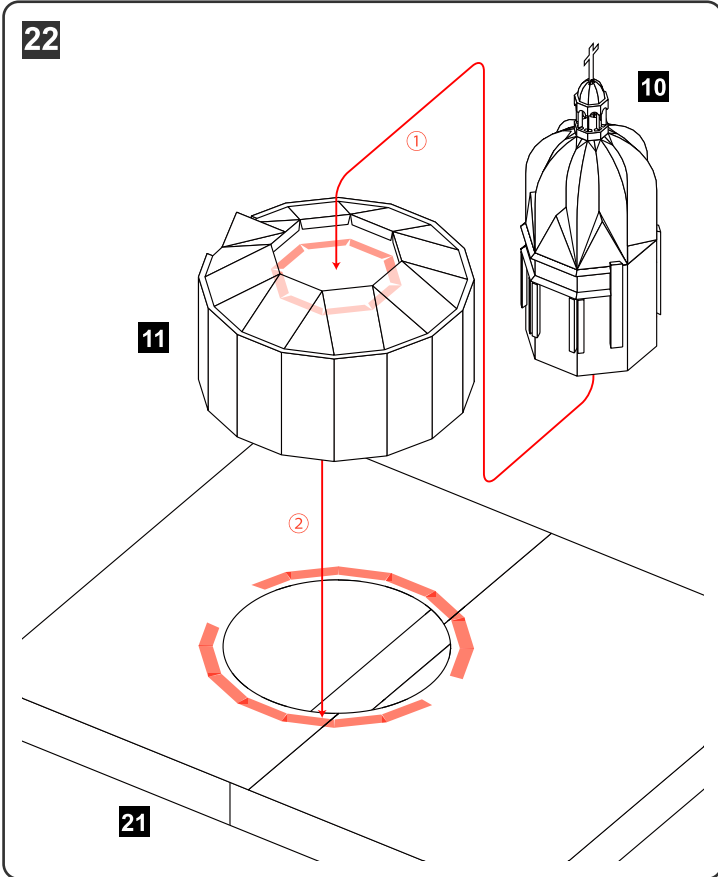





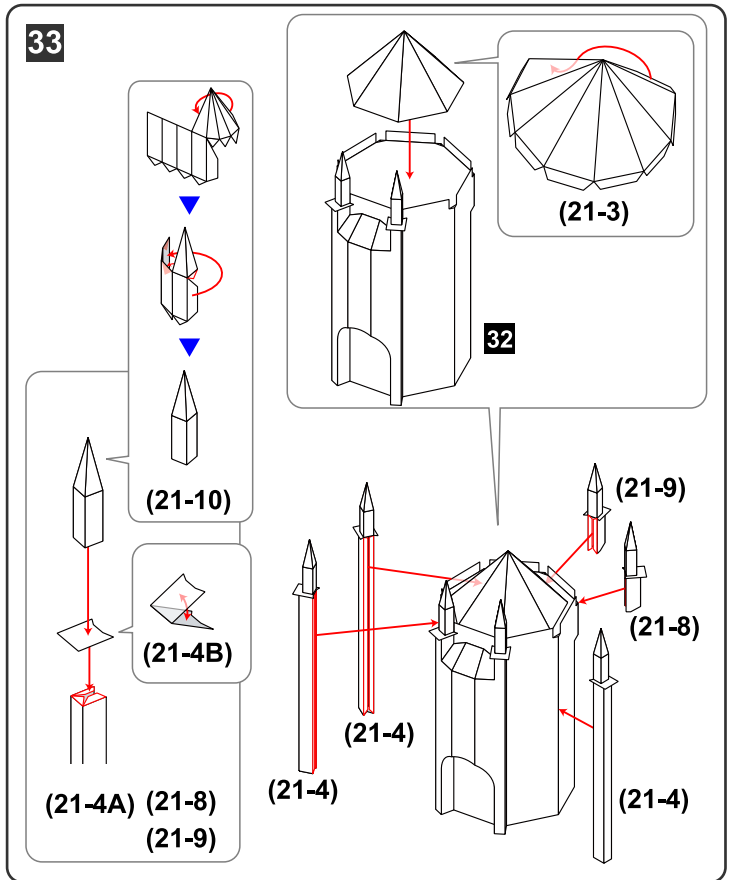
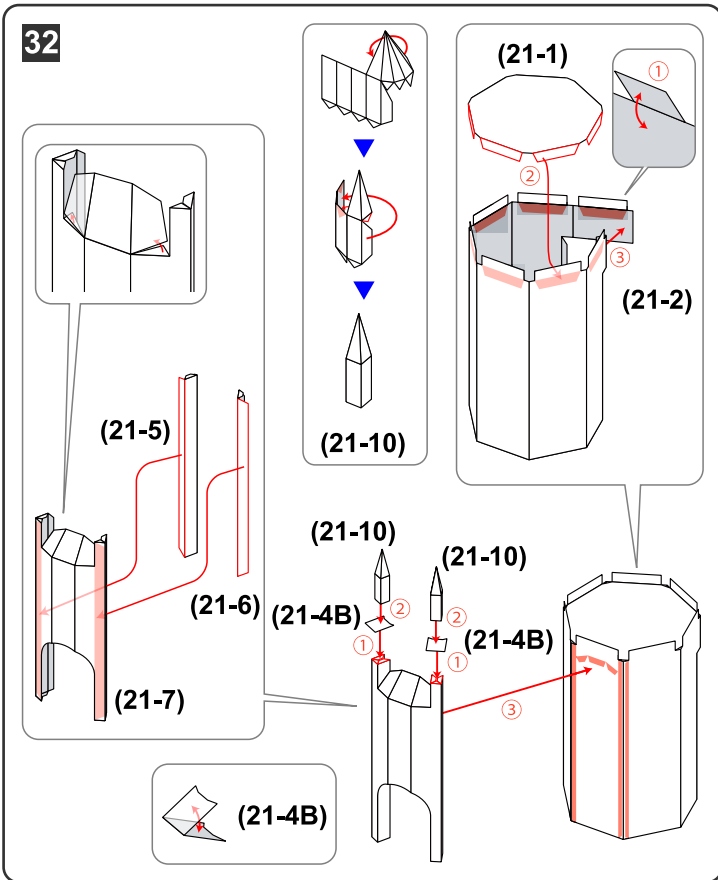
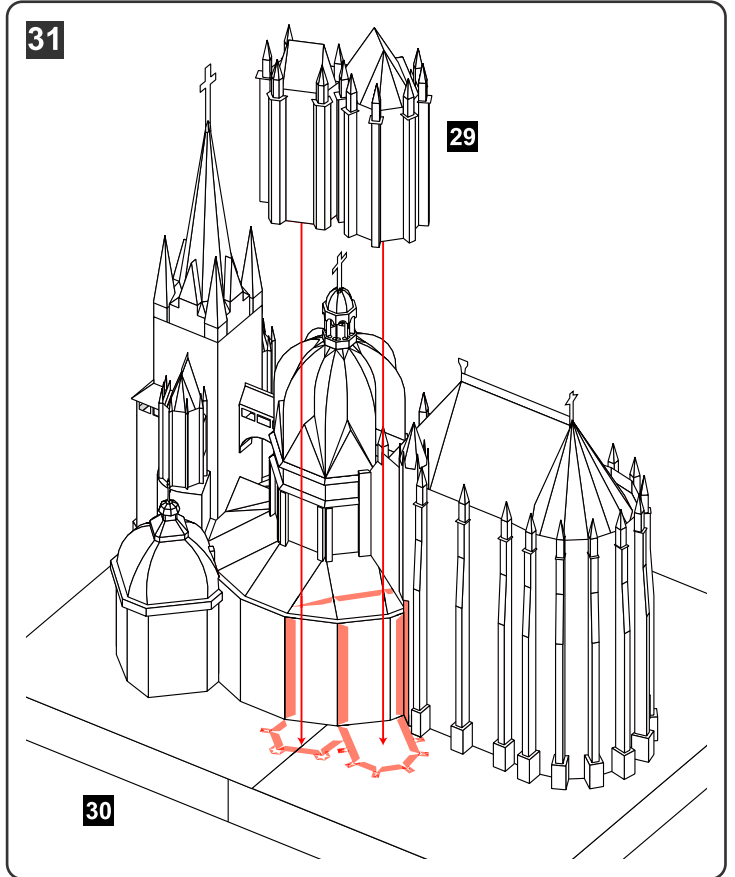
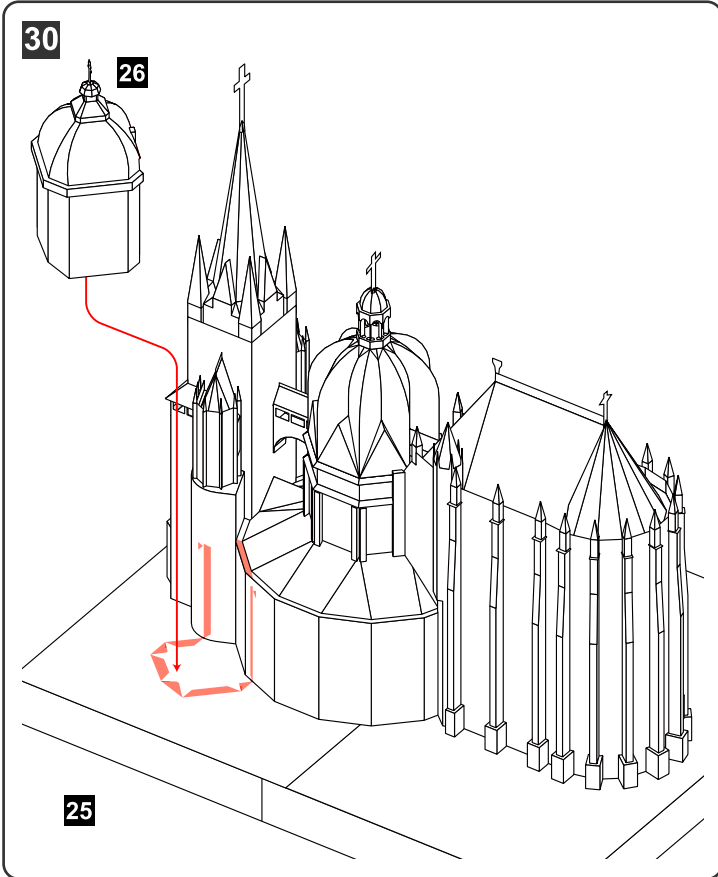

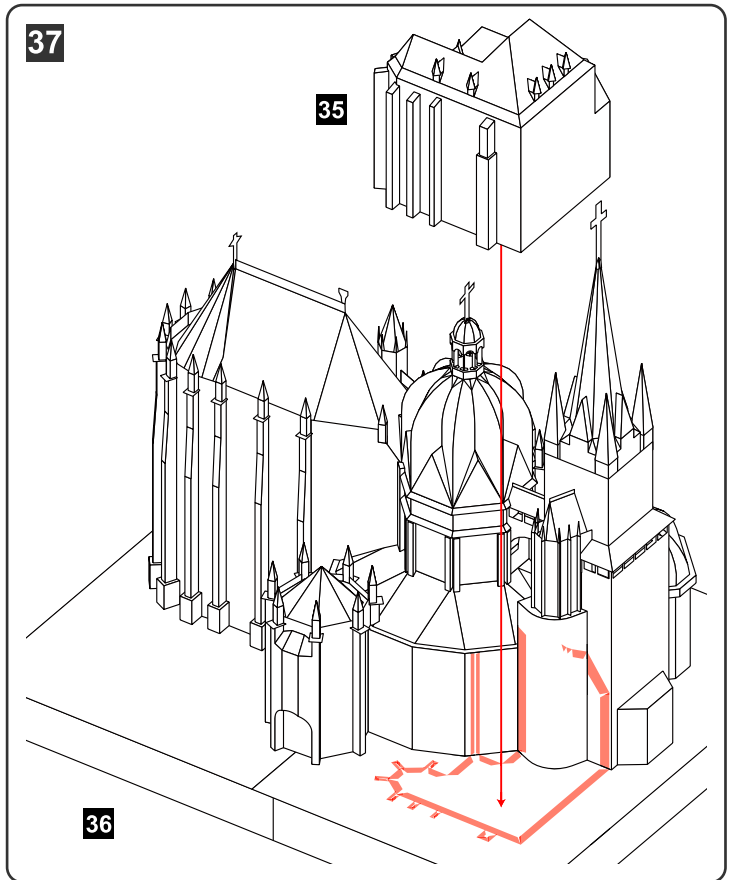
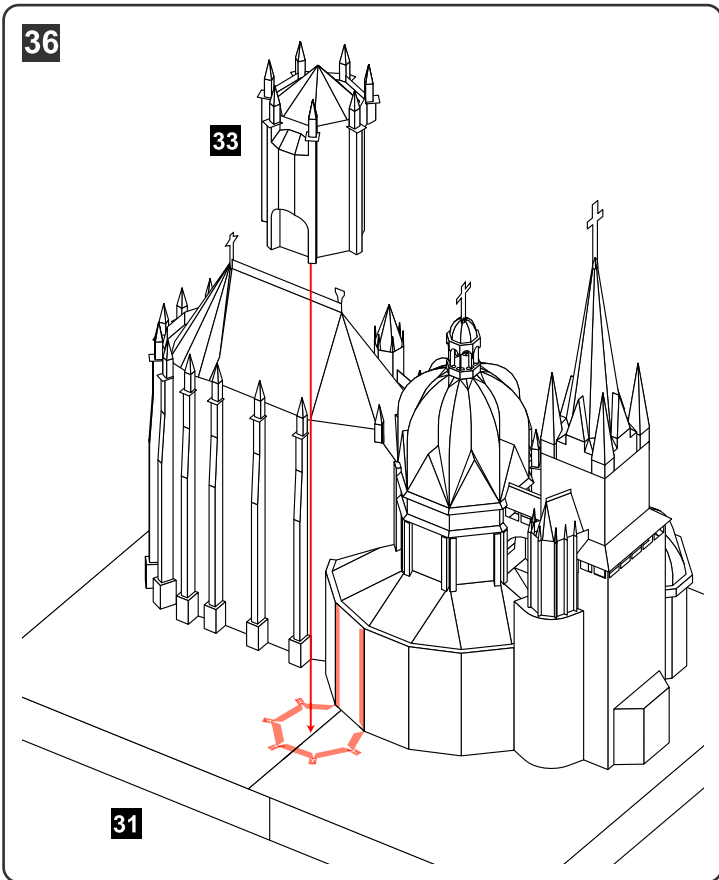
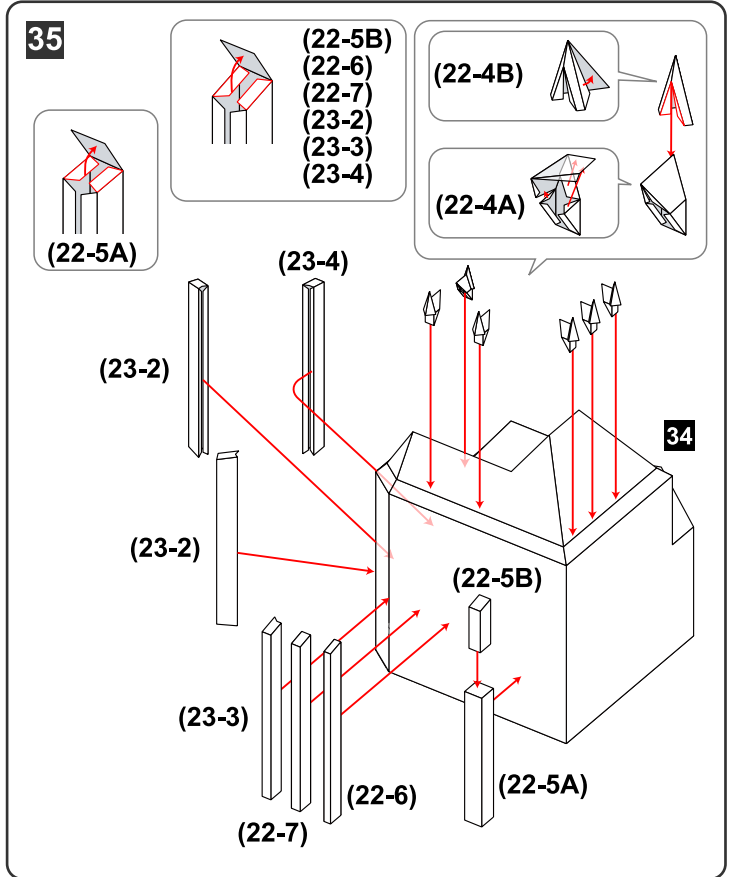
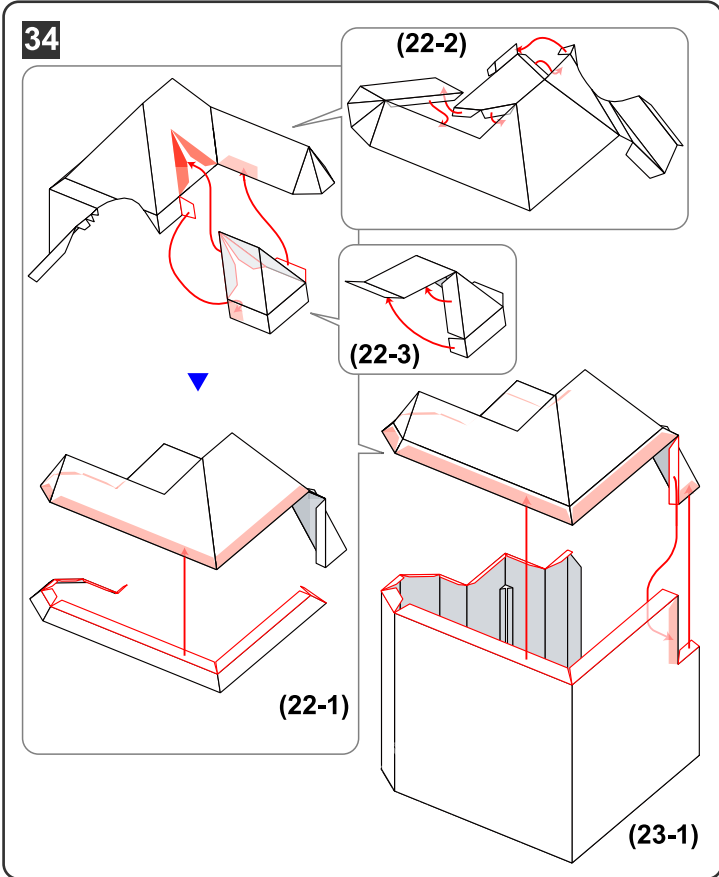



38

